

Phoenix 0930 Series Saracen

Designed to meet the need for a modern, compact, security safe for hotel, residential and business use.

- The Saracen Series is fitted with a high security electronic motorized lock that features a clear LCD display for ease of use.
- Attractive, unobtrusive and simple to use with its advanced 'user friendly' digital lock. It offers discreet protection in any situation.
- The advanced design complements any home or business and disguises a spacious interior.
- The safe is recommended for a cash risk of £1,500 or Valuables risk of £15,000*
- Ready prepared for floor fixing. (Bolts Supplied).



Phoenix 0930 Series Saracen

The body is constructed from galvanised steel plate with a solid steel door 5mm thick. The highly secure electronic lock is simple to operate and can be programmed with an easy to remember personal code, giving many millions of potential combinations.

The security and power status of the safe is always shown by the LED display and a tone alert. The electronic combination also has an advanced, built in anti tamper lockout system which freezes the lock once the incorrect combination has been entered 3 times consecutively.

The Phoenix Saracen is suitable for fixing to the floor or wall. Its easy to install basefixing system gives added strength and security when fixed to any concrete, wood or asphalt floor or when bolted to a wall. Every Phoenix Saracen has:

1. 2 years unconditional guarantee on labour and parts
2. Free, 24 hour locksmith emergency service (UK and USA only)
3. Supplied complete with wall and floor fixing kits

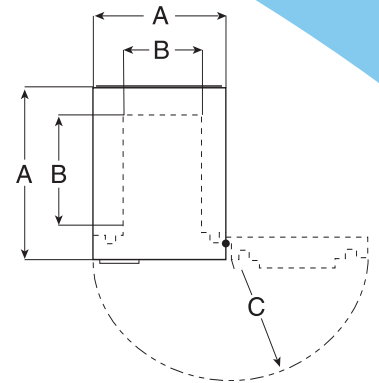

● **Dimensions stated as:**

- A External height x width x depth
- B Internal height x width x depth
- C Door swing
- D Weight
- E Capacity
- F No of shelves, No of drawers, No of doors

● **Saracen 0931**

- A 250mm x 350mm x 250mm
- B 220mm x 345mm x 180mm
- C 300mm
- D 12kg
- E 14 litres

● **Saracen 0932 Laptop Safe**

- A 229mm x 432mm x 360mm
- B 200mm x 427mm x 290mm
- C 380mm
- D 16kg
- E 25 litres

● **Saracen 0933**

- A 560mm x 370mm x 445mm
- B 532mm x 363mm x 375mm
- C 295mm
- D 31kg
- E 75 litres

DEALER'S STAMP

All weights and sizes are approximate.

All Phoenix Fire Safes come with a Free lifetime 'after the fire' replacement warranty and a full two year materials and labour warranty.

Phoenix policy is one of constant improvement. We therefore reserve the right to alter any part of the specification achieved in this publication without incurring any obligation.



Certificate No. 1059/96

0930 / 3 07 GB